

b+s ApplicationLink & b+s HostLink

ApplicationLink and HostLink from Bucher + Suter integrate desktop applications and external databases to Cisco's Unified Contact Center Enterprise (UCCE).

ApplicationLink integrates third-party desktop applications to the contact center, allowing agents to handle interactions such as telephone calls, e-mail, chat, fax and Voice Mail within existing Graphical User Interfaces.

HostLink connects Databases to Cisco contact centers. One particularly useful HostLink application is host-based routing. During the routing of an interaction, the system performs a Database dip and uses customer information to select the appropriate agent and pop a screen.

The following call flow demonstrates a typical HostLink integration:

1. A customer service call arrives at the contact center.
2. The system uses the customer's telephone number to look up status and language data in an external Database. UCCE uses that information to route the customer to the best skilled agent to handle that particular type of call.
3. The agent receives a screen pop of customer information and can answer the call appropriately.

Advantages:

ApplicationLink:

- Pops customer information and enables voice, e-mail, chat, web call back, fax and Voice Mail interaction handling within the existing CRM application.
- Integrates a wide variety of third-party applications to the Cisco contact center environment.
- Displays agent status information within the Graphical User Interface.

HostLink:

- Connects multiple Databases to Cisco's Unified Contact Center Enterprise.
- Existing customer information can be used for host-based routing.

The Avaloq banking system's multi-media enabled agent interface shown below is a good example of ApplicationLink's ability to integrate CRM applications to Cisco's Unified Contact Center Enterprise. Agents can handle an array of different interactions without having to switch between applications.

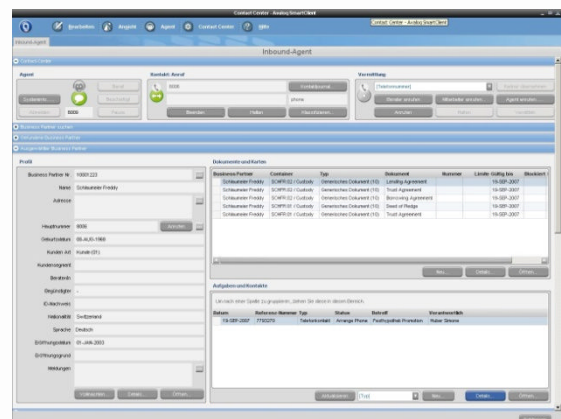

Functionality:

ApplicationLink integrates with a variety of third-party applications to enable the following media channels:

- Telephony
 - Inbound call
 - Outbound call
 - Transfer
- Multi-channel
 - Voice Mail
 - e-mail
 - Chat
 - Fax

HostLink provides database integration to:

- Perform queries
- Update internal and external Databases
- Create tickets for interactions routed to the contact center.

The following diagram illustrates the connection of third-party applications via ApplicationLink and the connection of databases via HostLink to Cisco's Unified Contact Center Enterprise.

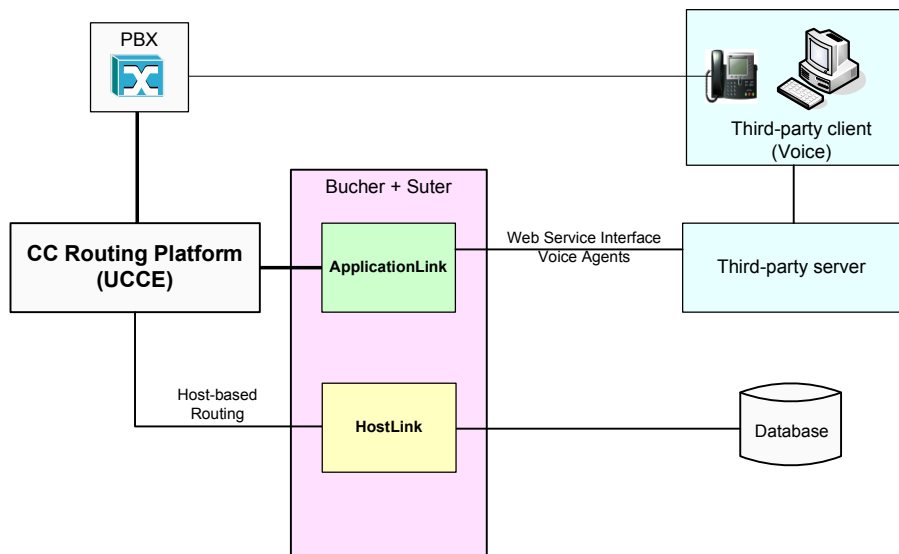

Technical Data:

ApplicationLink:

- Client-client
Example: Peregrine
- Server-server
Examples: SAP CRM, MS CRM etc.
- Multi-channel solutions
Examples: Talisma, Avaloq

HostLink:

- Databases
 - MSSQL
 - My SQL
 - DB2
- Applications
 - ARS Remedy
 - CTI OS

Benefits:

- Increased efficiency by allowing agent to continue to use a single, familiar GUI desktop interface.
- Investment protection by integrating, rather than replacing, existing applications.
- Skills based routing and screen pops based on database lookups.

Bucher + Suter AG

Arastrasse 6
CH- 3048 Worblaufen/Bern
T +41 31 917 52 00 / F +41 31 917 52 50
info@bucher-suter.com, www.bucher-suter.com

Bucher + Suter AG

Donnersbergstrasse 1
D-64646 Heppenheim
T +49 6252 674 6000 / F +49 6252 674 619
info@bucher-suter.de , www.bucher-suter.de